

D^2T^2 Analysis of an Offshore Deluge System Availability and Reliability

Leonardo Leoni^a, John Andrews^b, Filippo De Carlo^a

^aUniversity of Florence, Florence, Italy

^bUniversity of Nottingham, Nottingham, United Kingdom

Organiser use only: Received date; revised date; accepted date

Keywords: Fault Tree, Petri Net, Safety Analysis, Safety barriers, Dependency modelling

The Fault Tree (FT) method remains the prevalent approach for performing the analyses of complex systems, but it harbors certain limitations. These include assumptions constant failure and repair rates, or the independence of events (Yan et al., 2017). Moreover, it is not able to model complex maintenance strategies, which have progressively become more popular. The recently introduced Dynamic and Dependent Tree Theory (D^2T^2) algorithm has been developed to cope with the former limitations (Tolo and Andrews, 2022). The typical limitations of a FT could be overcome by integrating Petri Nets (PNs), Markov models (Meshkat et al., 2001), and Binary Decision Diagram (BDD). Indeed, PNs and Markov models could allow to obtain a dynamic model (Zhang et al., 2009), while the traditional FT is a static technique. On the other hand, BDD is an advantageous representation of a FT, and it avoids approximation (Sinnamon and Andrews, 1996). Thus, it is adopted in the interest of efficiency and accuracy.

The application of the D^2T^2 along with its advantages have been tested on a cooling system of a pressure vessel (Andrews and Tolo, 2023; Tolo and Andrews, 2022). However, the more common FT analysis is a general technique, which could be employed in several fields. Accordingly, to be a proper competitor, the generalizability capability of the D^2T^2 algorithm should be properly verified. Furthermore, in its original form, the D^2T^2 approach has not been specifically tailored for a safety barrier. Thus, it is required to investigate what is required to model a safety barrier through the D^2T^2 , knowing that a safety barrier requires an availability analysis and a reliability analysis for the standby and operating phase respectively (Meshkat et al., 2000).

Based on the former considerations, this study investigates the application of the D^2T^2 methodology to an offshore fire deluge system as a typical safety barrier of offshore platforms. The choice is related to the importance of the Oil & Gas sector and the considered system. Indeed, previous studies have conducted a reliability analysis of a fire deluge system by considering traditional tools such as FT (Andrews and Dugan, 1999).

An offshore fire deluge system serves as a critical safety barrier in the event of a fire outbreak within one of the platform's compartments. Fig. 1 illustrates a schematic representation of this system. The system operates by distributing water around the platform via a ring main, which is pressurized by a set of jockey pumps. In the scenario of a fire in any module of the offshore platform, two sensors are tasked with detecting the presence of the fire. These sensors are a Heat Sensor (HS) and a Smoke Sensor (SS). Upon detecting the fire, either sensor sends a signal to a Display Panel (DP), alerting the Operator (OP). Subsequently, the operator activates the system by pressing an Activation Button (AB). The Activation Button triggers opens the Valve (V1), allowing water to flow from the main ring into distribution pipes. The water is spread through sprinkler nozzles (NOZ). This directs water to the area affected by the fire. As water exits the system, the ring main experiences a drop in pressure. Three

sensors (S1, S2, and S3) are tasked with monitoring the pressure within the ring main. If at least two out of the three sensors detect a pressure drop, a signal is sent to a Computer (COMP), which activates an electric pump (P1). Should any failure involve the electric pump, electric motor, or electric supply, a diesel pump (P2) acts as a backup.

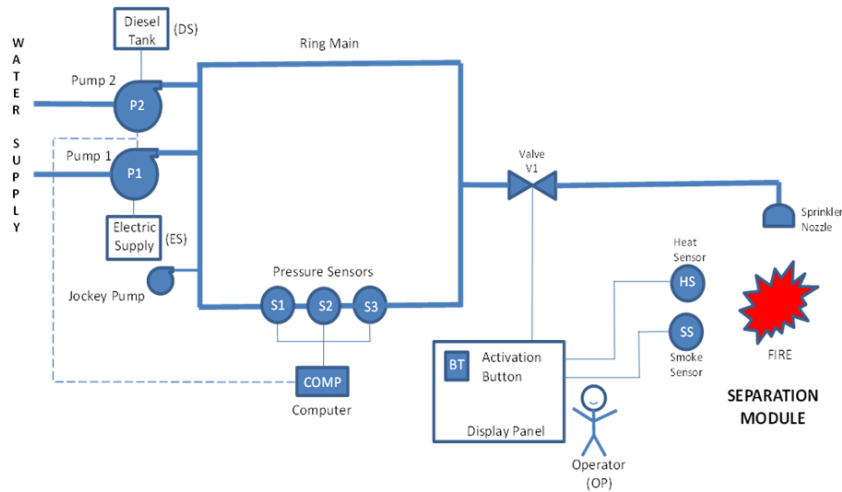

Fig. 1. Schematic representation of a fire deluge system and its main components

As the system under consideration functions as a safety barrier, it primarily remains in a standby state. In this state, it's assumed that all components are subjected to an inspection every three months. Additionally, the system is expected to operate for a maximum of 24 hours in the event of a fire, during which maintenance activities cannot take place. The focal point of investigation here is: "System failure to supply water to the sprinklers in the event of a fire." In this context, the following complexities and dependencies are considered:

- Pressure sensors are subjected to common cause failures;
- Water supplies are subjected to opportunistic maintenance;
- The diesel pump system is in cold standby with the electric pump system
- The motors follow a Weibull failure behaviour during the operating phase.

The application of the D^2T^2 algorithm is described along with the required considerations for a safety barrier. Accordingly, this is a first step for proving the generalizability of this novel approach, along with proving its effectiveness in modeling a system that spends most of its time in a non-operating state.

Acknowledgements

This work was supported by the Lloyd's Register Foundation, a charitable foundation in the U.K. helping to protect life and property by supporting engineering-related education, public engagement, and the application of research.

References

- Andrews, J., Tolo, S., 2023. Dynamic and dependent tree theory (D2T2): A framework for the analysis of fault trees with dependent basic events. *Reliab. Eng. Syst. Saf.* 230, 108959.
- Andrews, J.D., Dugan, J.B., 1999. Dependency modeling using fault tree analysis, in: *Proceedings of the 17th International System Safety Conference*.
- Meshkat, L., Dugan, J.B., Andrews, J., 2001. Maintenance modelling for computer-based systems. *Proc. Inst. Mech. Eng. Part E J. Process Mech. Eng.* 215, 221–231. <https://doi.org/10.1177/095440890121500305>
- Meshkat, L., Dugan, J.B., Andrews, J.D., 2000. Analysis of safety systems with on-demand and dynamic failure modes, in: *Annual Reliability and Maintainability Symposium. 2000 Proceedings. International Symposium on Product Quality and Integrity (Cat. No. 00CH37055)*. IEEE, pp. 14–21.
- Sinnamon, R.M., Andrews, J.D., 1996. Quantitative fault tree analysis using binary decision diagrams. *J. Eur. Systèmes Autom.* 30, 1051–1071.
- Tolo, S., Andrews, J., 2022. An integrated modelling framework for complex systems safety analysis. *Qual. Reliab. Eng. Int.* 38, 4330–4350. <https://doi.org/10.1002/qre.3212>
- Yan, R., Jackson, L.M., Dunnett, S.J., 2017. Automated guided vehicle mission reliability modelling using a combined fault tree and Petri net approach. *Int. J. Adv. Manuf. Technol.* 92, 1825–1837. <https://doi.org/10.1007/s00170-017-0175-7>
- Zhang, X., Miao, Q., Fan, X., Wang, D., 2009. Dynamic fault tree analysis based on Petri nets, in: *2009 8th International Conference on Reliability, Maintainability and Safety*. IEEE, pp. 138–142.